

Technical Data Sheet

Working Pressure: 450 psi Working Temperature: 0°C to 45°C
 Assembly Drawing: 1MNC 3032 Design Code: PED

Product Code: 8E450N Issue: [always request current issue]

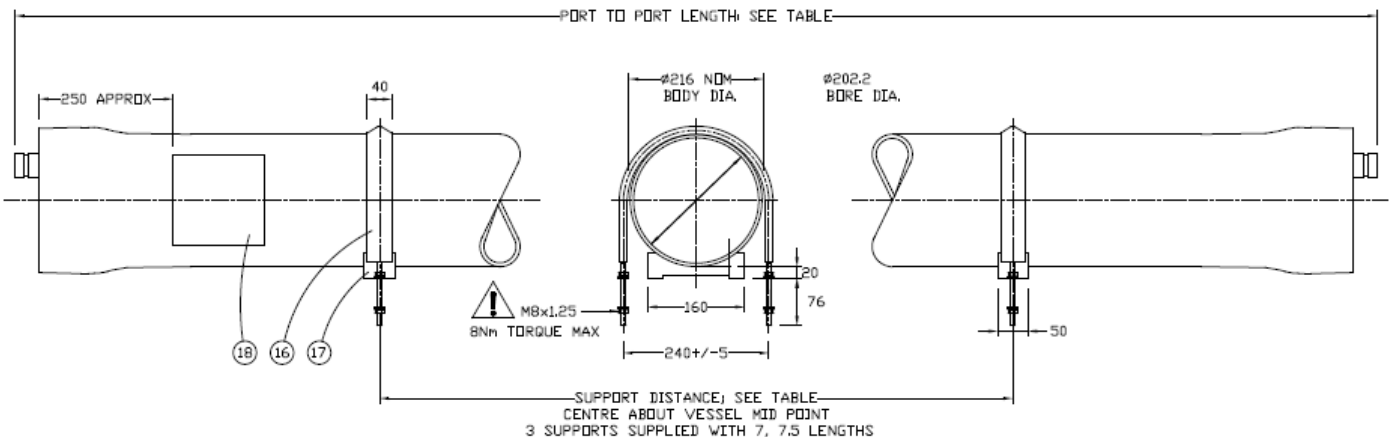

Order Reference	No. of 40" Elements	Port to Port Length +/- 7 mm	2 Support Positions Max/Min	3 Support Positions Max/Min	Max Dry Weight kg
8E450N.1	1	1556	1100/700	-	25
8E450N.1.5	1.5	2064	1400/1000	-	30
8E450N.2	2	2572	1800/1300	-	35
8E450N.3	3	3588	2400/1800	2400/1800	45
8E450N.4	4	4604	2950/2400	3250/2400	55
8E450N.4.5	4.5	5112	3200/2800	3700/2800	60
8E450N.5	5	5620	3450/3150	4150/3150	66
8E450N.6	6	6636	4000/3800	5000/3800	76
8E450N.7	7	7652	-	5850/4850	86
8E450N.7.5	7.5	8160	-	6200/5350	92

Feed & Concentrate Connections: 1.5" BSP (Female)

Product Connections: 1.0" BSP (Female)

Body of vessel is manufactured completely from glass reinforced epoxy resins. Pressure vessels can be produced to cover all leading manufacturers' membranes regardless of length. Please advise membrane type and length when requesting further details. Please adhere to recommended support positions. If in doubt, contact Phoenix Vessel Technology.

NB: CONFIRM WITH PHOENIX VESSEL TECHNOLOGY THAT YOU ARE WORKING TO THE LATEST DIMENSIONS PRIOR TO ANY RIG DESIGN WORK

All dimensions in mm

All dimensions and weights are nominal unless stated otherwise

Technical Data Sheet

Product Code: 8E450N Issue: [always request current issue]

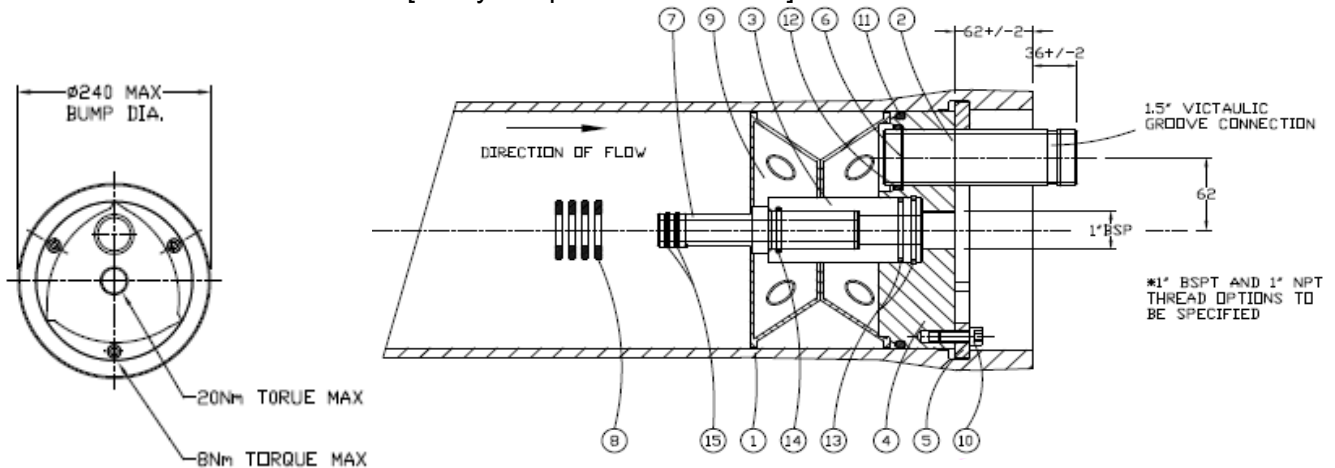

User Guide on our Website

DO NOT EXCEED THE MAXIMUM TORQUE

Item	Description	Material	Part No.	Qty	
1	Vessel Body	Glass Fibre Epoxy Resin	BDY 3112	1	
2	Feed Concentrate Port	ST. ST. 316L	CMP 2476	2	
3	Hub	UPVC	CMP 1550	2	
4	End Cap	PP Thermoplastic	1" BSP	CMP 2884	2
			1" BSPT	CMP 2885	
			1" NPT	CMP 2886	
5	Retaining Ring Set	Glass Fibre	CMP 2526	6	
6	Spiroloc Circlip	Stainless Steel-316	CMP 3062	2	
7	Adaptor	Thermoplastic	To Suit Membrane	2	
8	Shims	ABS (included in item 7 above)	CMP 1674	8	
9	Thrust Ring	Thermoplastic	CMP 4211	1	
10	Cap Head Screw	ST. ST.-A2	CMP 1520	2	
11	'O' Seal End Cap	EPDM	BS-882	2	
12	'O' Seal Feed/End Cap	EPDM	BS-327	2	
13	'O' Seal Hub/End Cap	EPDM	BS-225	4	
14	'O' Seal Prod/Adaptor	EPDM	BS-219	2	
15	'O' Seal Adaptor	EPDM	To Suit Membrane	4	
16	Strap	ST. ST./PVC	CMP 3426	2/3	
17	Saddle	Urethane	CMP 3919	2/3	
18	Name Plate	Vinyl	PV 141	1	

Phoenix Vessel Technology
Limited
Unit 2, The Old Bakery
Lower Tuffley Lane
Gloucester
GL2 5DP UK

The company reserves the right to alter specifications without prior notice.

Contact Phoenix Vessel Technology to request latest issue.

For lubricants and general assembly refer to the

T:+44 (0) 1452 311673
E: adam.stait@ravago.com
www.phoenixvessel.co.uk

