

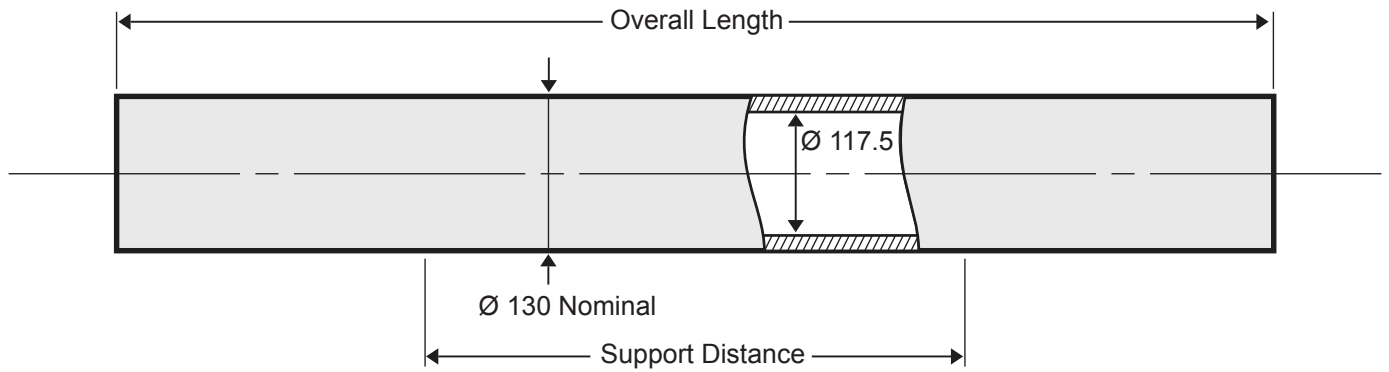

4.625" End Port Pressure Vessel 250 psi (17.2 bar)

ORDER REFERENCE
See Box Below



Working Pressure: 250 psi

Working Temperature: 0° to 45° C

Assembly Drawing: 1MNC 1257

Design Code: PED

Body of vessel is manufactured completely from glass reinforced epoxy resins. Pressure vessels can be produced to cover all leading manufacturers membranes regardless of length. Please advise membrane type and length when requesting further details. Please adhere to recommended support positions, if in doubt contact Phoenix Vessel Technology.

Feed and concentrate connections: 1/2" BSP (Female)

Concentrate connections: 1/4" BSP (Female)

Product connections: 3/8" BSP (Female)

Order Reference	No of 40" Elements	Overall Length +/-4mm	Max Suport Position	Min Support Position	Max Dry Weight
4.6E250N.11	11"	425	300	200	3.2 kg
4.6E250N.19	19"	625	500	200	4.2 kg
4.6E250N.41	41"	1184	800	200	7.0 kg
4.6E250N.41/2	41"x2	2225	1550	400	12.2 kg

4.625" End Port Pressure Vessel 250 psi (17.2 bar)

ORDER REFERENCE
See Box Below

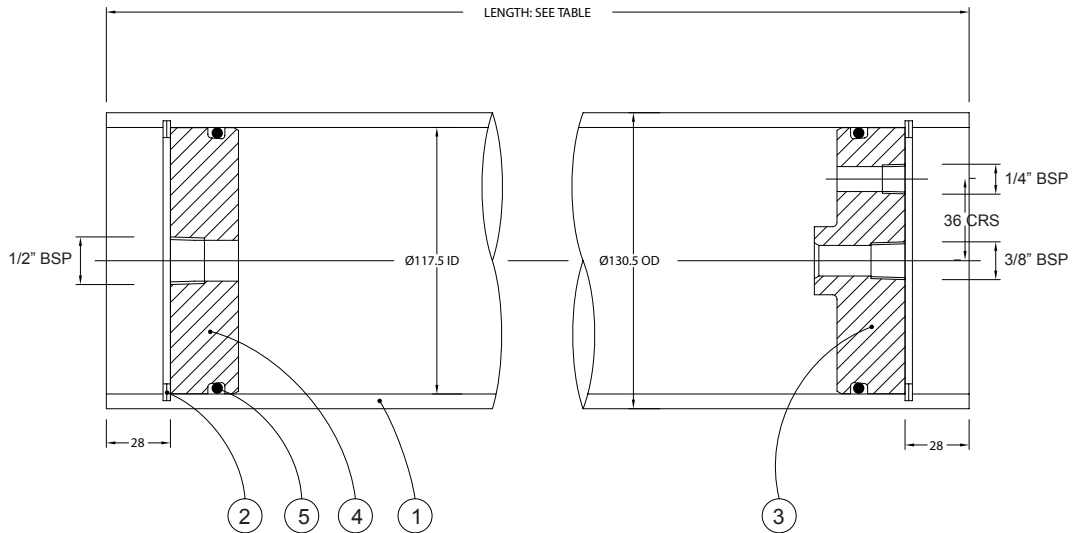

NOTES

1. Glycerine to be used on all 'O' seal paths.

Item	Description	Material	Part No.	No.off
1	Vessel Body	Glass Fibre Epoxy Resin	BDY 1343	1
2	Circlip	St.Steel	CMP 1346	2
3	End Cap A	Thermoplastic	CMP 1344.A	1
4	End Cap B	Thermoplastic	CMP 1345.A	1
5	'O' Seal (End Cap)	EPDM Included in item 3 & 4	BS347	2
6	'O' Seal (Adapt/Element)	EPDM Included in item 7	BS012	1
7	Adaptor	Thermoplastic	CMP 1766.A	1

The company reserves the right to alter specifications without prior notice.
This data sheet supersedes all previous issues. Product Code: 4.6E250N ISSUE:E

OPTIONS:

1. Adapter (8.9.)

DO NOT EXCEED THE MAXIMUM TORQUE.

For lubricants and general assembly refer to the **User Guide** on our website.