

## 8" End Port Pressure Vessel 600 psi (41.40 bar)

**ORDER REFERENCE**  
See Box Below

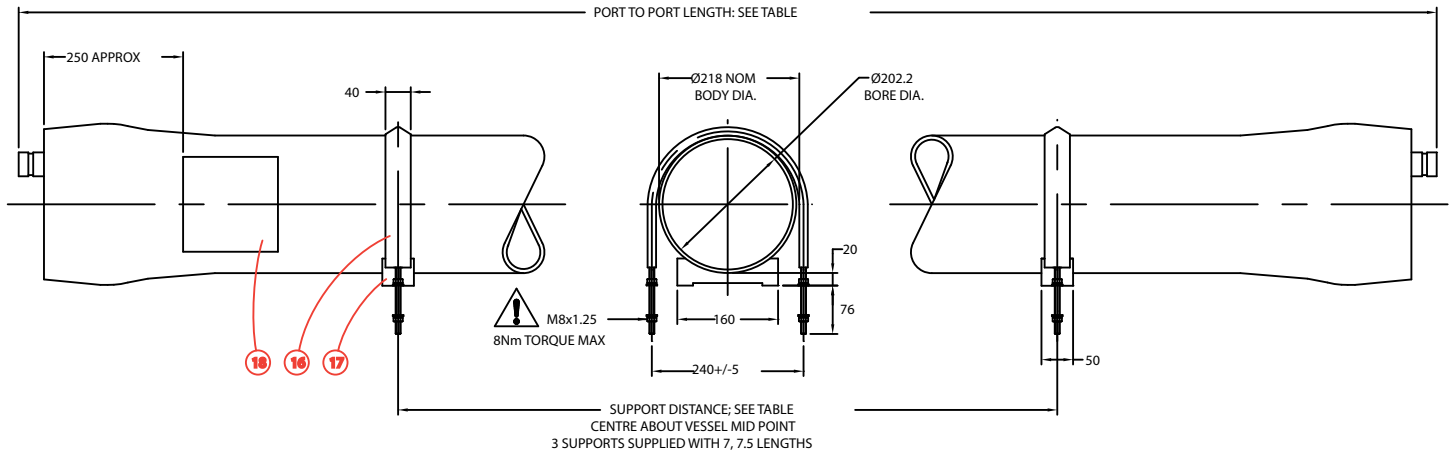

**Working Pressure:** 600 psi

**Working Temperature:** -7° to 45°C

**pH Range:** 3 - 10

**Assembly Drawing:** 1MNC 3610

**Design Code:** PED

Body of vessel is manufactured completely from glass reinforced epoxy resins. Pressure vessels can be produced to cover all leading manufacturers membranes regardless of length. Please advise membrane type and length when requesting further details. Please adhere to recommended support positions, if in doubt contact Phoenix Vessel Technology.

**Feed and concentrate connections:** 1.5" Victualic.

**Product connections:** 1.0" BSP Parallel (Female)

Order Reference	No of 40" Elements	Port to Port Length +/-7mm	2 Supports Max/Min	3 Supports Max/Min	Max Dry Weight
8E600N.1	1	1626	1100 700	- -	26 kg
8E600N.1.5	1.5	2134	1400 1000	- -	31 kg
8E600N.2	2	2642	1800 1300	- -	36 kg
8E600N.3	3	3658	2400 1800	2400 1800	46 kg
8E600N.4	4	4674	2950 2400	3250 2400	56 kg
8E600N.4.5	4.5	5182	3200 2800	3700 2800	61 kg
8E600N.5	5	5690	3450 3150	4150 3150	67 kg
8E600N.6	6	6706	4000 3800	5000 3800	77 kg
8E600N.7	7	7722	- -	5850 4850	87 kg
8E600N.7.5	7.5	8230	- -	6200 5350	93 kg

## 8" End Port Pressure Vessel 600 psi (41.40 bar)

**ORDER REFERENCE**  
See Box Below

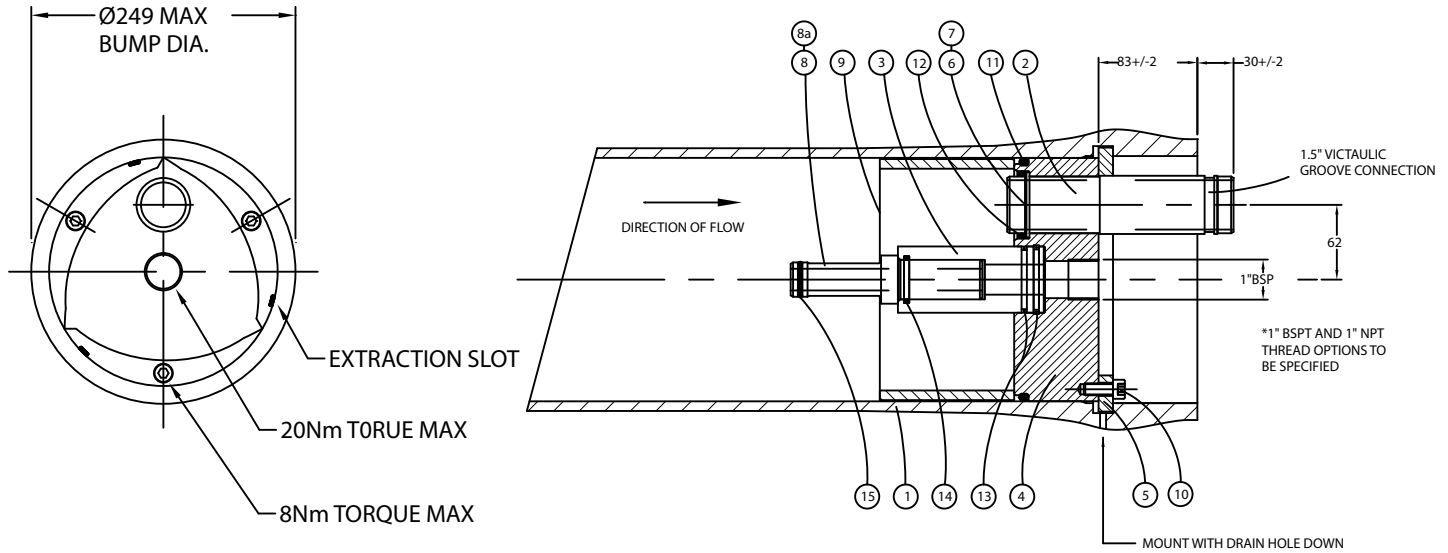

Item	Description	Material	Part No.	No. off
1	Vessel Body	Glass Fibre Epoxy Resin	BDY 3658	1
2	Feed/Concentrate Port	St. Steel - 316	CMP 3703	2
3	Hub	UPVC	CMP 1550.A	2
4	End Cap	Polypropylene	CMP 3512.A	2
5	Retaining Ring Segment	Glass Fibre	CMP 2528	2
6	Spiroloc Circlip	St. Steel 302 Included in item 2	CMP 3062	2
7	Circlip Bearing Washer	St. Steel 304	CMP 3598	2
8	Adaptor	Thermoplastic	To suit membrane	2
8a	Adaptor Spacer Shims (To suit membrane)	Thermoplastic	CMP 1674	8
9	Thrust Ring	Thermoplastic	CMP 1228	1
10	Cap Head Screw	St. Steel A2	CMP 1520	6
11	'O' Seal End cap	EPDM Included in item 5	BS882	2
12	'O' Seal Feed/End Cap	EPDM Included in item 2	BS327	2
13	'O' Seal Hub/End Cap	EPDM Included in item 3	BS225	4
14	'O' Seal Prod/Adaptor	EPDM Included in item 3	BS219	2
15	'O' Seal Adaptor	EPDM	To suit membrane	2/4
16	Strap	St. Steel/PVC	CMP 3426.A	2/3
17	Saddle	Urethane	CMP 1075	2/3
18	Nameplate	Vinyl	Not Available	1

The company reserves the right to alter specifications without prior notice.

This data sheet supersedes all previous issues. Product Code: 8E600N 12/10

Tighten all bolts/nuts to 50% of the maximum torque figure.

**DO NOT EXCEED THE MAXIMUM TORQUE.**

For lubricants and general assembly refer to the [User Guide on our website](#).